

NO	DESCRIPTION	MATERIAL	Q'TY	FINISH	REMARK
1	SHELL	BRASS	1	GOLD	B-SMA0043-G
2	GASKET	SI RUBBER	1	RUBBER	RU-0008
3	INSULATION	TEFLON	1	TEFLON	I-0115T
4	WASHER	PH.BRONZE	1	GOLD	W-0012
5	BODY	BRASS	1	GOLD	B-SMA0046-G
6	PIN	BRASS	1	GOLD	P-SMA0037-G
7	RING	BRASS	1	GOLD	R-0007-G

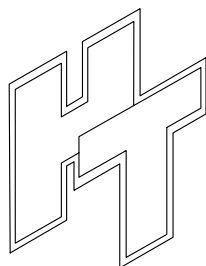
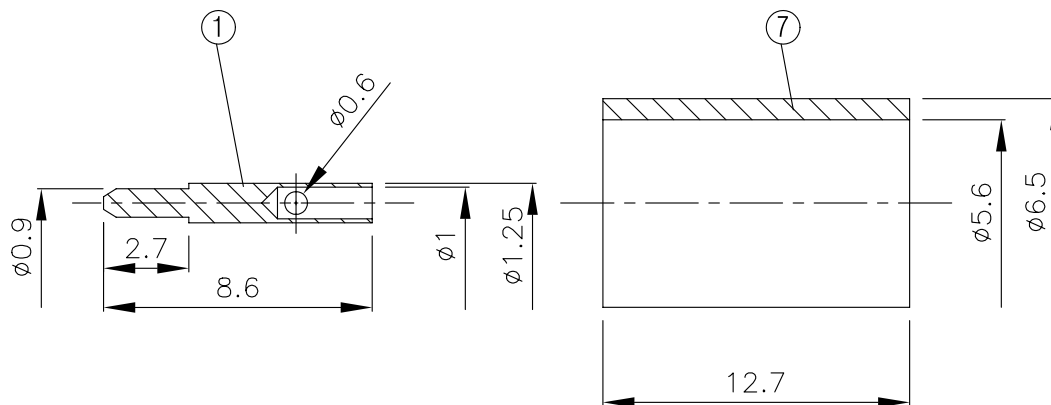
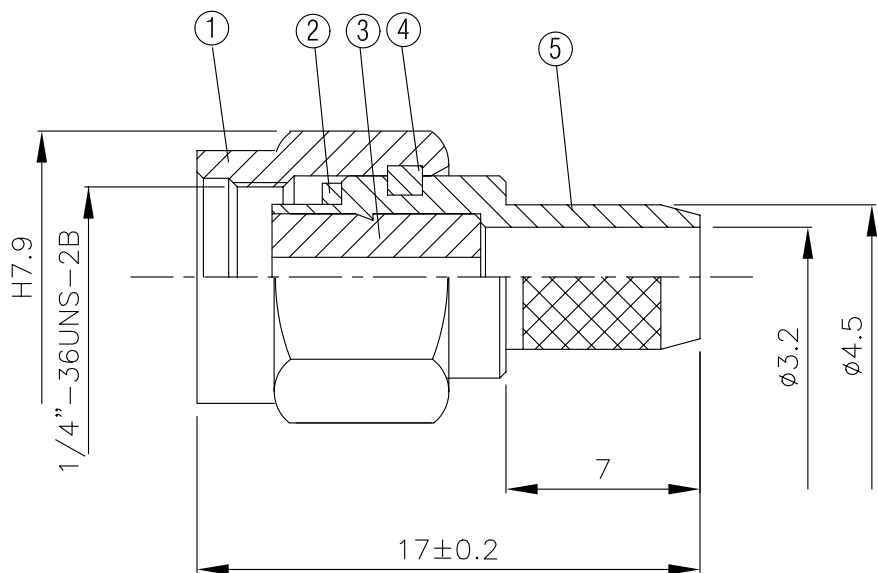
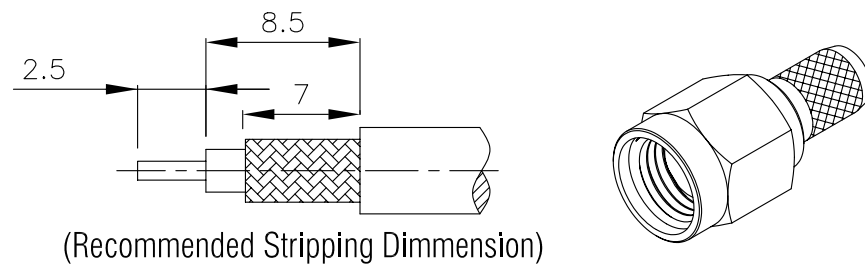

HUS-TSAN GROUP CO., LTD.

P.O. BOX 40-76. TAINAN. TAIWAN, R.O.C.

TITLE SMA MALE CRIMP FOR RG58U, 141A/U

PART NO. SMA-03F-TGG

DRAWING NO. SMA-03F-TGG

DRAWN MARY DATE 96.03.19

CHECKED 沈佳憶 DATE

Q.A. 蘇姿潔 DATE

APPROVAL 徐燦霖 DATE

REVISION DATE

DIMENSIONS ARE IN MILLIMETERS

UNLESS OTHERWISE SPECIFIED TOLERANCE

0.5-5=±0.2	120-315=±1
5-30=±0.4	315-1000=±1.6
30-120±0.6	1000-2000=±2.4

SCALE 4:1 SIZE A

REVISION

DESCRIPTION	ENGINEER